

INSTALL INSTRUCTIONS

C-TSM-CV-D and C-TSM-CV-P

1996-2008 CROWN VICTORIA

DRIVER and PASSENGER - TRUNK SIDE MOUNTS

TOOLS REQUIRED:

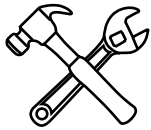

- Drill with 1/8" and 3/16" drill bits
- Open End Wrench - 3/8"
- Phillips Screwdriver

HARDWARE:



QTY:	DESCRIPTION:	PART #:
3	10/32 X 1/2" Machine Screw	GSM33118
3	10/32 Keps Nut	GSM30028
3	#10 x 3/4" Sheet Metal Screw	GSM33195

LINE DRAWING:

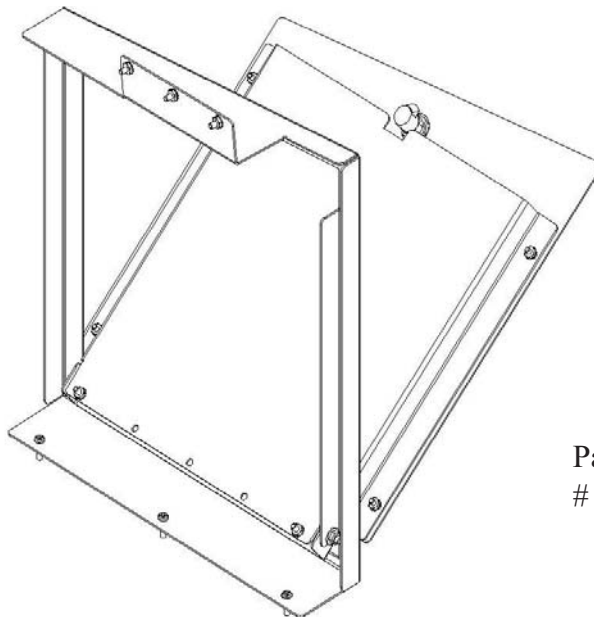

Passenger Side shown
C-TSM-CV-P

Always!

- Read all instructions before installing any Havis-Shields Equipment Corp products.
- Check for obstructions (Wire, brake lines, fuel tank, etc.) before drilling any holes!
- Use hardware provided with install kit
- For product support: visit the Install Instructions Section of our website at <http://havis.com/Installation/Installation.html>, email technicalsupport@havis.com or call 1-800-524-9900.



Installation:



Position frame assembly as shown. Trunk liner does not have to be removed, but you may want to cut it as needed to improve access for routing wires.



Top frame mount attaches to the trunk gasket mounting flange. Drill three holes with a 3/16" (.187") drill bit.



Bottom frame mount attaches to the trunk side floor. Drill three pilot holes with a 1/8" (.125") drill bit.

* Always check under floor before drilling *



Attach top frame with three (3) - 10/32" x 1/2" machine screws and keps nuts.



Attach bottom frame with three (3) - # 10 x 3/4" sheet metal screws.



Driver side Trunk Side Mount complete.

Install electrical components as desired.